



**Bobcat®**

**COMPACT EXCAVATORS**

**E10z**



***One Tough Animal®***

# E10z — SPECIFICATIONS

## Weights

Operating weight with TOPS canopy and bucket (ISO 6016)	1176 kg
Transport mass (no attachment)	1077 kg
Ground pressure with rubber tracks	29.70 kPa

## Engine

Make / model	Kubota / D722-E4B-BCZ-6
Fuel	Diesel
Number of cylinders	3
Displacement	0.72 L
Maximum power @ 2000 rpm (ISO 14396)	7.5 kW
Maximum torque (SAE)	40.1 Nm

## Performance

Digging force, dipperstick (ISO 6015)	5550 N
Digging force, bucket (ISO 6015)	8294 N
Drawbar pull	9905 N
Travel speed, low range	2.1 km/h
Travel speed, high range	3.1 km/h

## Hydraulic System

Pump type	Double gear pump
Total hydraulic capacity	20.00 L/min
Auxiliary flow	20.00 L/min
Auxiliary relief	184.0-192.0 bar

## Slew System

Boom swing, left	67.0°
Boom swing, right	64.0°
Slew rate	9.0 RPM

## Fluid Capacities

Cooling system	3.00 L
Engine lubrication plus oil filter	3.50 L
Fuel reservoir	16.00 L
Hydraulic reservoir	2.60 L
Hydraulic system	10.10 L

## Environmental

Noise level LpA(EU Directive 2006/42/EC)	80 dB(A)
Noise level LWA(EU Directive 2000/14/EC)	93 dB(A)

## Standard Features

710 mm dozer blade / 1100 mm extended	Seat
180 mm rubber track	Two-speed travel
Auxiliary hydraulics on boom with quick couplers	TOPS canopy <sup>1</sup>
Control console locks	Vandalism protection
Horn	Water separator
Electronically activated track expansion	Work light
Hydraulically expandible undercarriage from 710 to 1100 mm	Warranty: 24 months, 2000 hours (whichever occurs first)
Retractable seat belt	

1. Tip Over Protective Structure (TOPS) – Meets requirements of ISO 12117

## Working Range

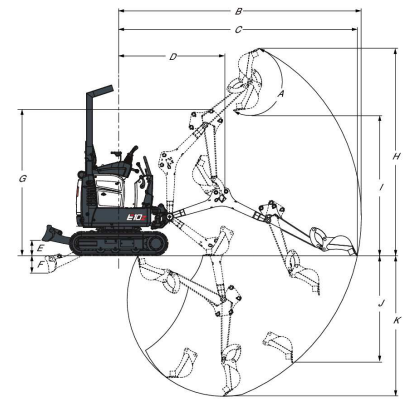

(A) 196.0°	(G) 1899.0 mm
(B) 3145.0 mm	(H) 2685.0 mm
(C) 3093.0 mm	(I) 1818.0 mm
(D) 1374.0 mm	(J) 1383.0 mm
(E) 196.0 mm	(K) 1820.0 mm
(F) 230.0 mm	

## Dimensions

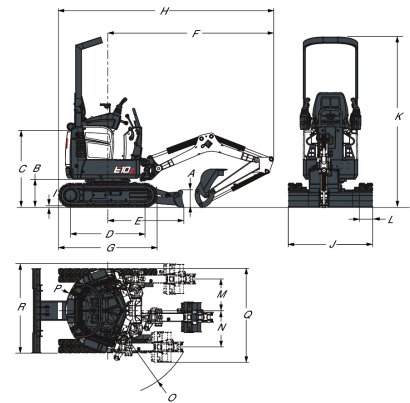

(A) 220.0 mm	(J) 710.0 mm
(B) 363.0 mm	(J) 1100.0 mm
(C) 992.0 mm	(K) 2209.0 mm
(D) 968.0 mm	(L) 180.0 mm
(E) 987.0 mm	(M) 413.0 mm
(F) 2153.0 mm	(N) 471.0 mm
(G) 1280.0 mm	(O) 1121.0 mm
(H) 2793.0 mm	(P) 550.0 mm
(I) 16.0 mm	

## Options

Auxiliary double action	Keyless ignition
Auxiliary on arm	LED light
Beacon	Object handling device (lifteye)
Heavy duty travel hose guard	Spark arrester muffler kit
Hydraulic oil cooler	Travel motion alarm



**Bobcat is a Doosan Company.**

Doosan is a global leader in construction equipment, power & water solutions, engines, and engineering proudly serving customers and communities for more than a century. | Bobcat and the Bobcat logo are registered trademarks of Bobcat Company in the United States and various other countries. ©2019 Bobcat Company. All Rights Reserved.

Certain specification(s) are based on engineering calculations and are not actual measurements. Specification(s) are provided for comparison purposes only and are subject to change without notice. Specification(s) for your individual Bobcat equipment will vary based on normal variations in design, manufacturing, operating conditions, and other factors. Pictures of Bobcat units may show other than standard equipment.



# Bobcat®

[www.bobcat.com](http://www.bobcat.com)