

RAMMERS

LIGHT COMPACTION EQUIPMENT



One Tough Animal

PURE COMPACTION POWER

► DURABLE AND EASY-TO-USE

These high-productivity, robust and cleverly designed machines make short work of any compaction needs on all terrains. Thanks to their robust and reliable engines, our rammers deliver high compaction power, while the clever engineering design keeps their center of gravity low for optimal balance.

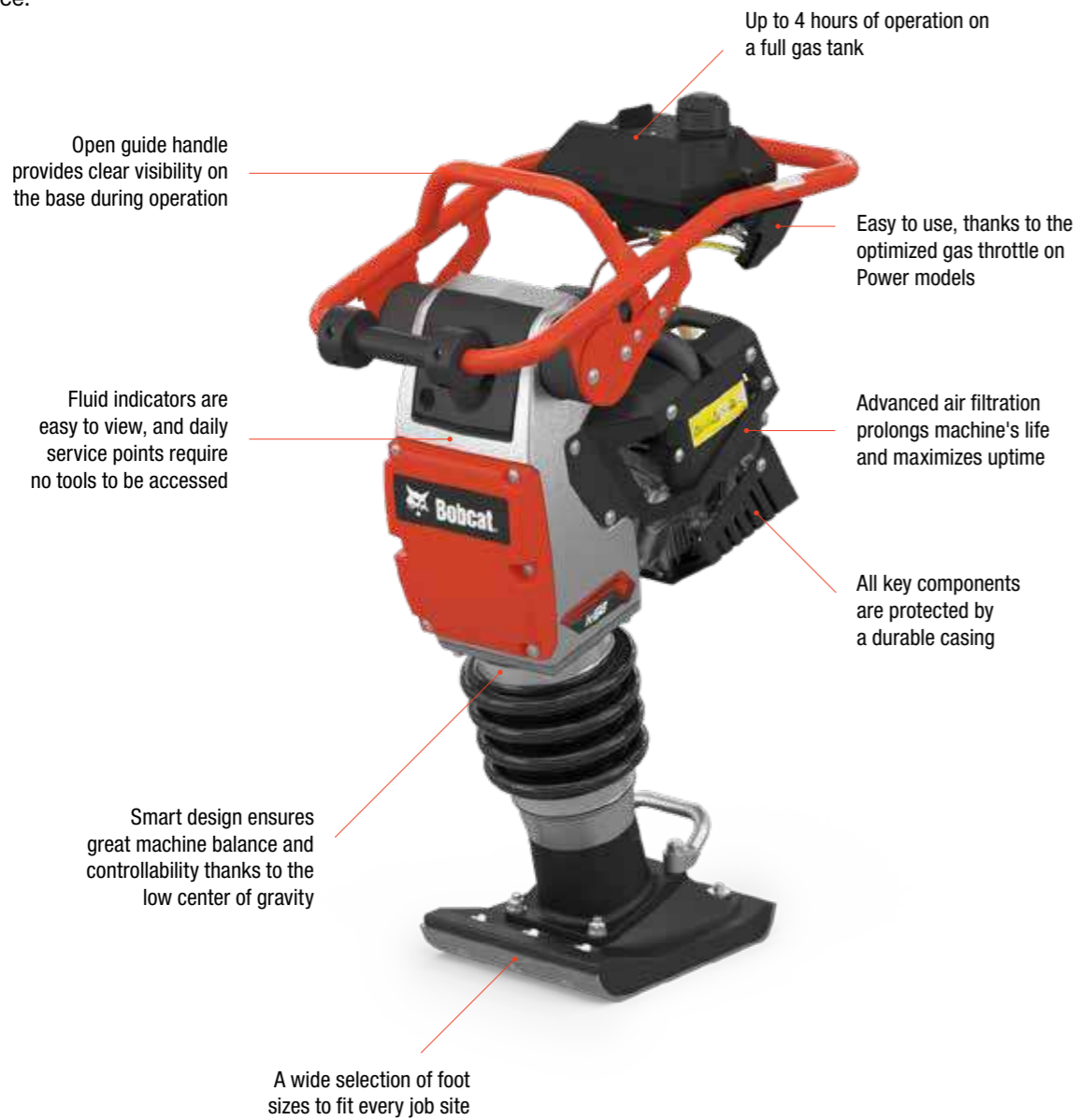

► HIGH PERFORMANCE

The compaction power is fully passed to the surface, thanks to the rammer's practical design. With such a powerful punch at your command, you are set to conquer any challenge.



► GREAT STABILITY

The well-balanced design of Bobcat's rammers provides you with easy control and prevents tipping. Boosting your efficiency while reducing your effort.



PERFORMANCE

EASY TO USE



▶ CLASSIC AND POWER

While our classic models provide plenty of power for most job sites, the R60 and R68 models also come in a technically advanced Power version. Featuring multi-function gas lever, low-emission petrol-powered Honda GXR120 engine (meeting the strictest regulations worldwide), and a double air filtration system extending product lifetime.



▶ PRECISION AND CONTROL

The handle's practical design allows for a secure grip from all sides and provides a direct line of sight to the foot of the rammer. This allows operators to work with precision, even in tight-fitting spaces.

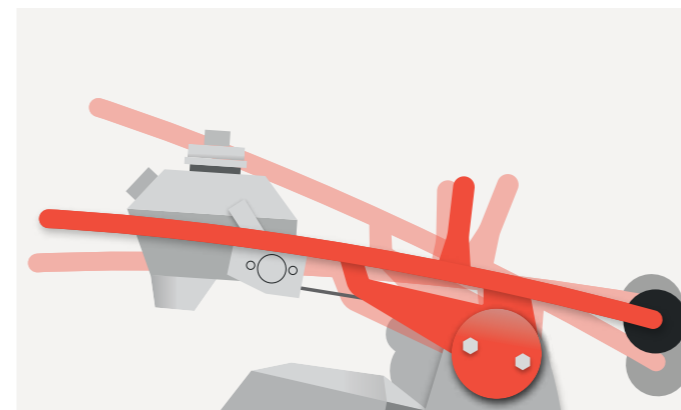

▶ ERGONOMIC SOLUTION

With the operator's comfort in mind, the handle is designed to isolate vibrations and reduce fatigue during long shifts. Furthermore, the handle is height adjustable, providing 3 height settings for optimized comfort.



▶ MINIMUM SERVICING, MAXIMUM UPTIME

Maintenance is quick and service points can be accessed without any tools. Self-cleaning filters further extend the rammer's uptime. And the clever horizontal placement of the air filter extends the machine's lifetime.



▶ APPLICATIONS

A small machine tackling big challenges. Bobcat rammers are exceptionally versatile machines thanks to their high productivity and small size. It's not the size after all. It's how many ways you can use it.

- Compaction in confined areas
- Earthwork
- Light to medium patchwork
- Pipeline and trench construction
- Landscaping and gardening

▶ BUILT TO LAST

Bobcat's construction equipment has always set the standard for durability and reliability. The careful selection of high-quality components and protective covers keep rammers working hard in the field, day after day.



CHOOSE YOUR ANIMAL

OPTIONS



▶ R30	
Weight	29 kg
Foot width	130 mm
Centrifugal force	2 kN

Specially designed for fiber optic application.



▶ R60	
Weight	62 kg
Foot width	280 mm
Centrifugal force	11.5 kN



▶ R60P	
Weight	62 kg
Foot width	280 mm
Centrifugal force	11.5 kN



▶ R68	
Weight	68 kg
Foot width	280 mm
Centrifugal force	13 kN



▶ R68P	
Weight	68 kg
Foot width	280 mm
Centrifugal force	13 kN



▶ R70D	
Weight	83 kg
Foot width	280 mm
Centrifugal force	16 kN

OPTIONS	R30	R60	R60P	R68	R68P	R70D
Cyclone pre-filter	-	•	•	•	•	-
Hour meter	-	•	•	•	•	•
Standard rammer shoe	130 mm			280 mm		
Alternative rammer shoes	80 mm			165-200-230-330-400 mm		230-400 mm
Asymetric rammer shoe (340 mm)	-	•	•	•	•	•
Transport wheels	-	•	•	•	•	•



▶ ALWAYS ON TIME
To make servicing easier, a vibration-activated hour meter can be fitted on the rammer to help you monitor working hours and ensure that maintenance needs are met on time.

▶ CYCLONE PRE-FILTER
This optional pre-filter lowers pressure on the air-filter, extending its lifetime up to 5 times and reducing total cost of ownership.

▶ TRANSPORT WHEELS
Move your rammer around the job site with speed. To start rolling, simply click to attach the wheel wagon beneath the rammer, without using any tools.



SPECIFICATIONS

SPECIFICATIONS						
	R30	R60	R60P	R68	R68P	R70D
DIMENSIONS & WEIGHTS						
Machine weight	29 kg	62 kg		68 kg		83 kg
A Foot length	260 mm	340 mm				
B Foot width	130 mm	280 mm				
C Handle length	660 mm	710 mm				770 mm
D Machine height	860 mm	1 120 mm	1 020 mm			980 mm
E Handle width	300 mm	355 mm				410 mm
ENGINE						
Engine	Honda GX 35	Honda GX 100	Honda GXR 120	Honda GX 100	Honda GXR 120	Yanmar L48
Fuel	Petrol					Diesel
Engine output at RPM	0.92 kW (1.23 HP) @ 5 500	2.2 kW (3 HP) @ 4 300	2.7 kW (3.7 HP) @ 4 300	2.2 kW (3 HP) @ 4 300	2.7 kW (3.7 HP) @ 4 300	3.2 kW (4.3 HP) @ 3 250
Fuel consumption	0.5 l/h	0.9 l/h	1 l/h	0.9 l/h	1 l/h	0.9 l/h
COMPACTION FORCES						
Percussion rate	13.3 Hz	11.3 Hz			12.2 Hz	
Stroke height	45 mm	65 mm				60 mm
Centrifugal force	2 kN	11.5 kN		13 kN		16 kN
Surface capacity	58 m ² /h / 94 m ² /h	227 m ² /h				210 m ² /h
Max. compaction performance*	30 cm	45 cm		50 cm		60 cm
MISCELLANEOUS						
Fuel tank capacity	0.63 l	3.2 l				2.5 l
Travel speed	12 m/min	13.5 m/min				12 m/min
Width of optional foot sizes	80 mm	165–200–230–330–400 mm				230–330 mm

*depending on ground conditions

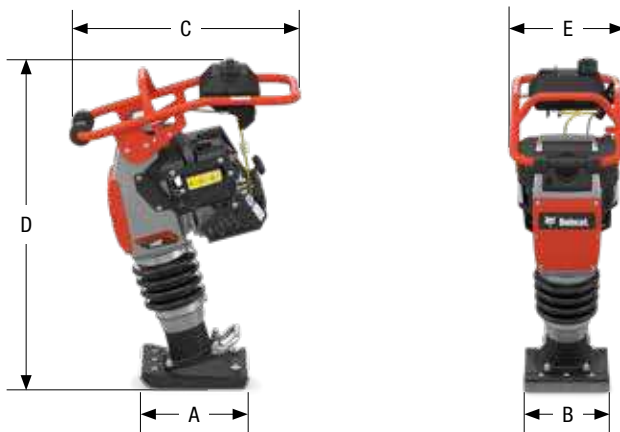

Certain specification(s) are based on engineering calculations and are not actual measurements. Specification(s) are provided for comparison purposes only and are subject to change without notice. Specification(s) for your individual Bobcat equipment will vary based on normal variations in design, manufacturing, operating conditions, and other factors. Pictures of Bobcat units may show other than standard equipment.



Bobcat is a Doosan Company.

Doosan is a global leader in construction equipment, power & water solutions, engines, and engineering proudly serving customers and communities for more than a century. | Bobcat and the Bobcat logo are registered trademarks of Bobcat Company in the United States and various other countries. ©2021 Bobcat Company. All Rights Reserved.

